

Allencap Bolts

2 Dimensions

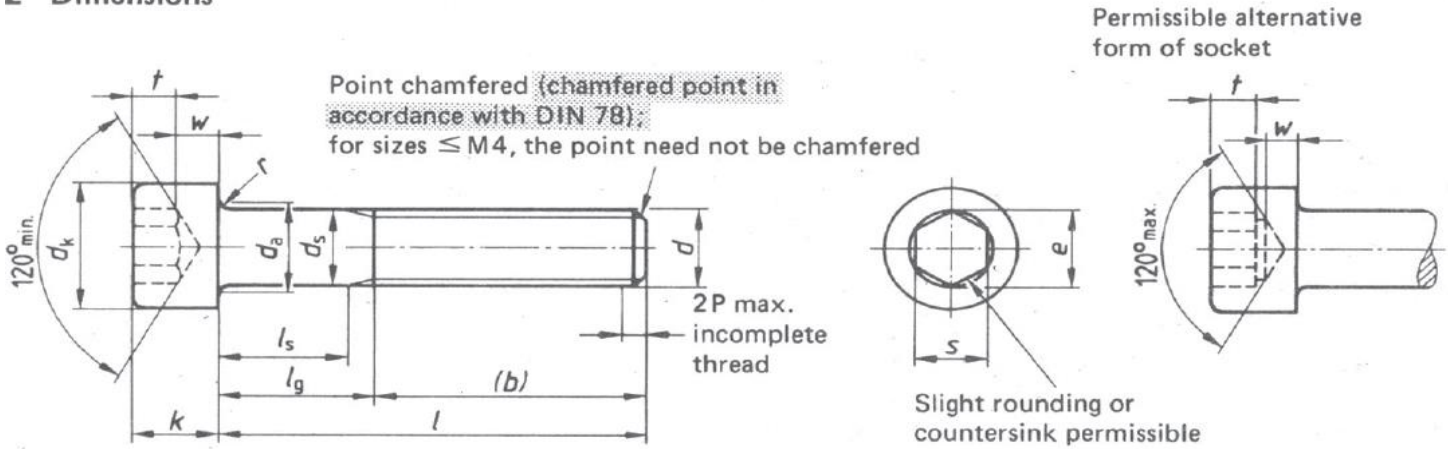

SIZE		M4	M5	M6	M8	M10	M12	M16	
PITCH DIA		3.44 3.52	4.36 4.45	5.24 5.32	7.04 7.16	8.86 8.99	10.68 10.82	14.50 14.66	
HALF THREAD START		30.00	30.00	35.00	40.00	45.00	55.00	65.00	
b	THREAD LENGTH	min.	20.00	22.00	24.00	28.00	32.00	36.00	44.00
l_s	BODY LENGTH	max.	L - 23.5	L - 26	L - 29	L - 34.25	L - 39.5	L - 44.75	L - 54
d_k	HEAD DIA.	min.	6.78	8.28	9.78	12.73	15.73	17.73	23.67
		max.	7.22	8.72	10.22	13.27	16.27	18.27	24.33
K	HEAD THICKNESS	min.	3.82	4.82	5.70	7.64	9.64	11.57	15.57
		max.	4.00	5.00	6.00	8.00	10.00	12.00	16.00
S	HEX SOCKET SIZE	min.	3.02	4.02	5.02	6.02	8.03	10.03	14.03
		max.	3.08	4.10	5.14	6.14	8.18	10.18	14.21
E	SOCKET CORNER	min.	3.44	4.58	5.72	6.86	9.15	11.43	16.00
T	SOCKET DEPTH	min.	2.00	2.50	3.00	4.00	5.00	6.00	8.00
w	WALL THICKNESS	min.	1.4	1.9	2.3	3.0	4.0	4.8	6.8
d_s	BODY DIA	min.	3.82	4.82	5.82	7.78	9.78	11.73	15.73
		max.	4.00	5.00	6.00	8.00	10.00	12.00	16.00